

NEW! LOWER CAPACITANCE

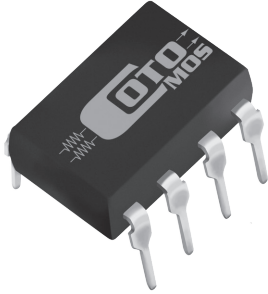

CotoMOS® CT330/CS330

The CT330 and CS330 feature current switching capability to 100mA with a low on resistance of 30Ω Maximum. Designed for Security, Industrial Controls, Measurement and Instrumentation applications the CotoMOS® relay is capable of handling 400V load conditions. If your requirements are different please contact your Coto Applications Engineer for assistance through www.cotorelay.com.

CT330/CS330 Features

- ▶ Contact Form: 2A
- ▶ Load Voltage: 400V Maximum
- ▶ Operation LED Current: 3.0mA Maximum
- ▶ Load Current: 100mA Maximum
- ▶ On-Resistance: 30Ω Maximum
- ▶ Low Off-State Leakage Current: 1.0μA Maximum
- ▶ I/O Breakdown Voltage: 1500Vrms Minimum
- ▶ Suffix -H for I/O Breakdown Voltage: 5000Vrms Minimum

DIMENSIONS
in Inches (Millimeters)

CT330

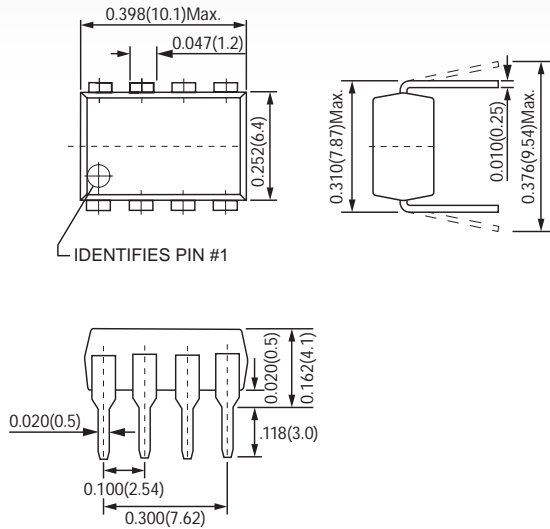

CS330

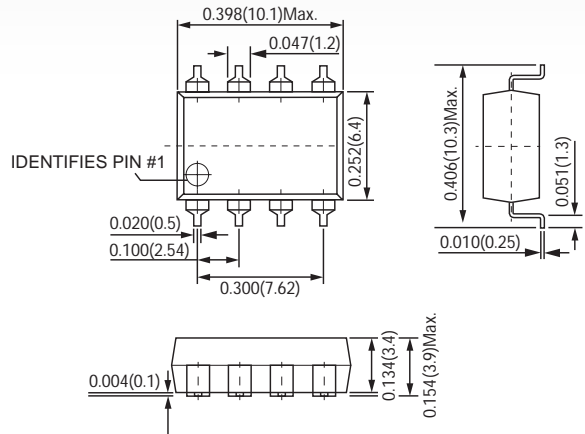

TERMINAL IDENTIFICATION

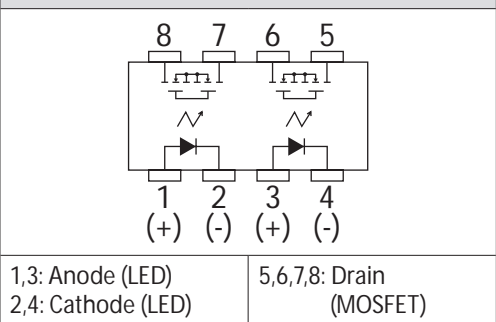

30 SERIES GRAPHS

