



Product Catalog

Advanced Switching and Magnetic Sensing Solutions

TMR TECHNICAL & APPLICATIONS INFORMATION

TMR SENSOR & SWITCH PACKAGING

Standard packaging is Tape & Reel containing 3,000 pieces. Below is a chart of Tape & Reel dimensions for standard TMR products.

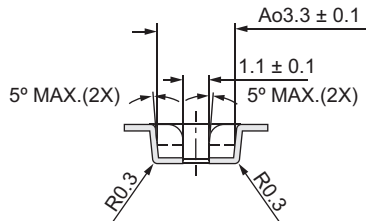
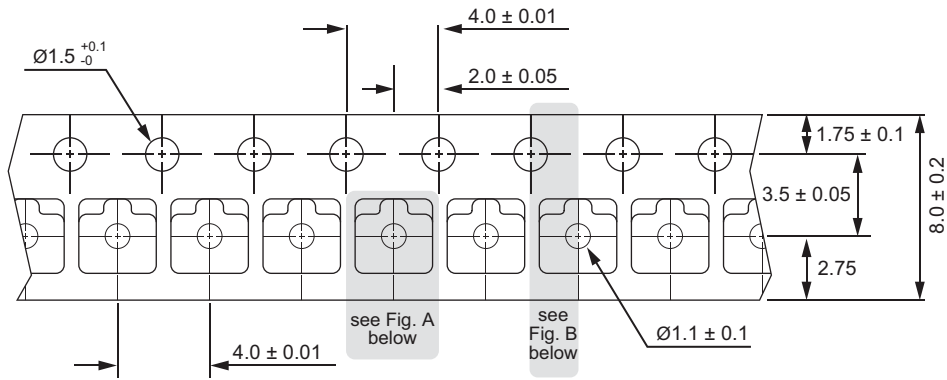

Fig. A

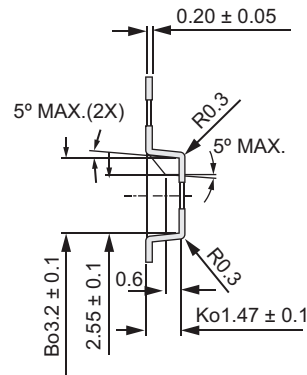
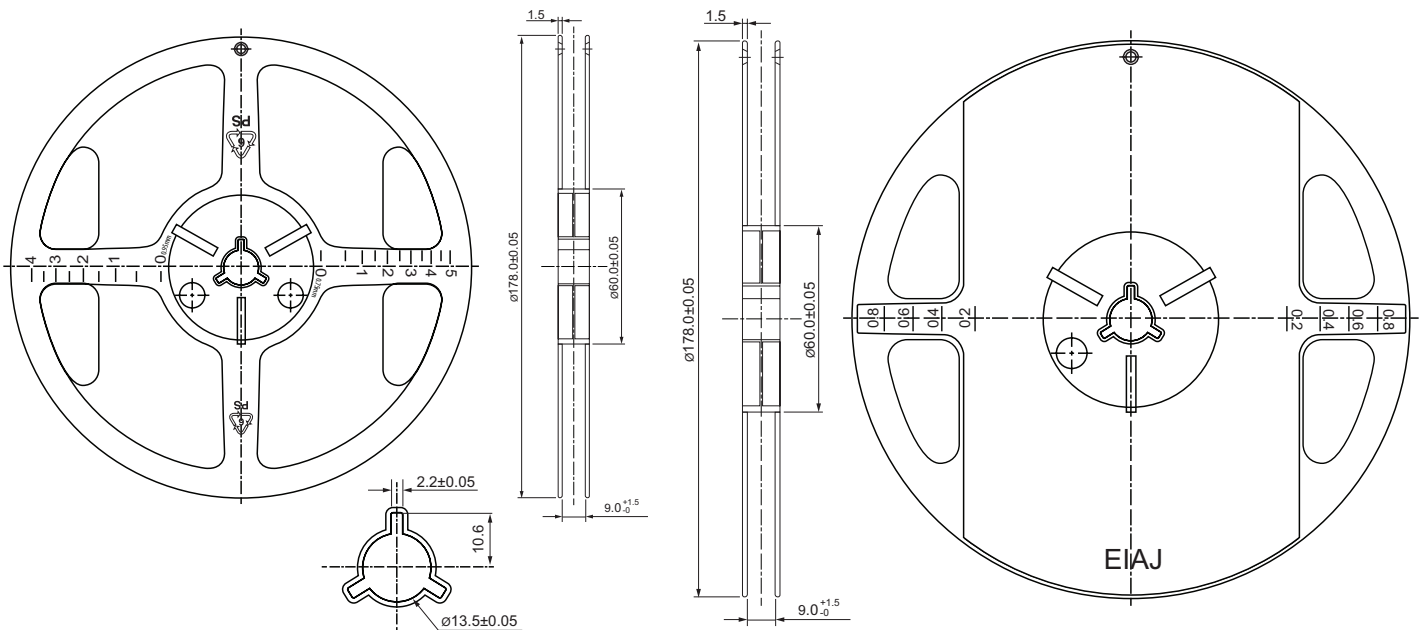
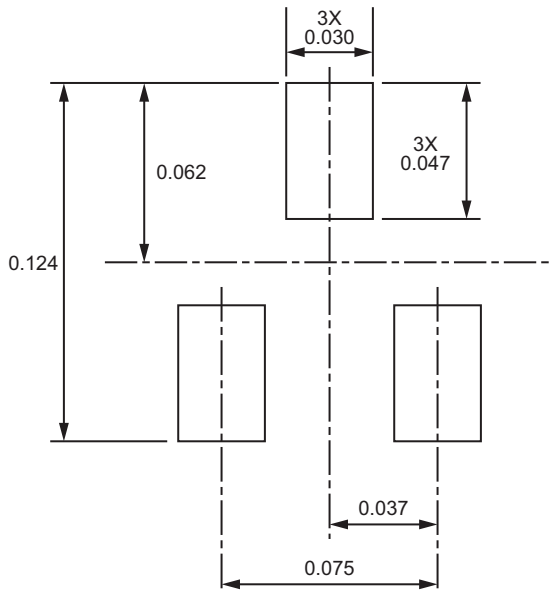

Fig. B



rev. 10212016

SUGGESTED SOLDER PAD LAYOUT



(Units in mm)

SUGGESTED REFLOW PROFILE

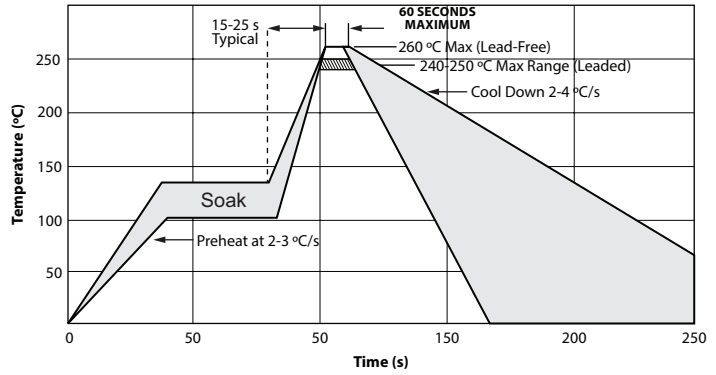

Notes:

1. Fully compatible with standard no-lead solder profile, 260 °C for 1 minute max (3 cycles max)
2. Profile shown as example. Users are advised to develop their own board-level profile
3. Temperature tolerance: +0 °C, as measured at any point on the package or leads
4. MSL listed on main specification page compatible with J-STD-020 or equiv.

TMR TECHNICAL & APPLICATIONS INFORMATION

GLOSSARY OF TERMS

Hysteresis: Hysteresis refers to the difference between two points of interest for a particular device. For digital sensors and switches, it represents the difference between the operate sensitivity and the release sensitivity, expressed either as an absolute value ($B_{OP} - B_{RP}$) or the % difference $(B_{OP} - B_{RP})/B_{OP}$. For an analog sensor, the hysteresis is the difference between the “magnet approach curve” and the “magnet recede curve.”

Magnet Approach Curve: The magnet approach curve is the characteristic change in resistance of an analog TMR sensor as an applied magnetic field approaches the sensor, typically plotted as a function of the magnetic field strength.

Magnet Recede Curve: The magnet recede curve is the characteristic change in resistance of an analog TMR sensor as an applied magnetic field recedes from the sensor, typically plotted as a function of the magnetic field strength.

Magnetoresistance: Magnetoresistance is a phenomenon wherein the electrical resistance of certain materials changes when exposed to an externally-applied magnetic field.

Magnetic Transfer Curve: The magnetic transfer curve defines the characteristic behavior of an analog TMR sensor by combining both the magnet approach curve and the magnet receive curve together.

Magnetic Tunnel Junction: A magnetic tunnel junction is a thin film structure consisting of two magnetic layers separated by a thin insulator. Because the insulating layer is thin enough (typically a few nanometers), electrons can tunnel from one magnetic layer into the other.

Operate Sensitivity: The operate sensitivity defines the upper limit of the strength of an applied magnetic field that a digital TMR sensor or switch must operate.

Operate Time: The operate time is the difference, in time, between the application of a magnetic field and the output response of the device. In an analog sensor, the response is a change in output resistance. In a digital sensor, the response is a change in state of the electrical output.

Release Sensitivity: The release sensitivity defines the lower limit of the strength of an applied magnetic field that a digital TMR sensor or switch must release.

Release Time: The release time is the difference, in time, between the removal of an applied magnetic field and the output response of the device. In an analog sensor, the response is a change in output resistance. In a digital sensor, the response is a change in state of the electrical output.

Tunnel Magnetoresistance (TMR): Tunnel Magnetoresistance is the magnetoresistive effect that occurs in a magnetic tunnel junction.

MAGNETIC SENSITIVITY MAPS

Magnetic sensitivity maps show the operate and release loci in three-dimensional space when a magnet is presented to a magnetically operated switch or sensor. The absolute operate and release distances between the magnet and the sensor will vary depending on the sensitivity of the switch and the strength of the magnet. However, the

shape and direction of the operate loci stay relatively constant except for cases where the magnet is physically much larger than the sensor. These plots were generated using a 2mm³ cubic shaped NdFeB N52 magnet with its North pole presented to the ground pin and a South pole presented to the opposite side.

RR120/RR130 Magnetic Sensitivity Pattern, perspective view

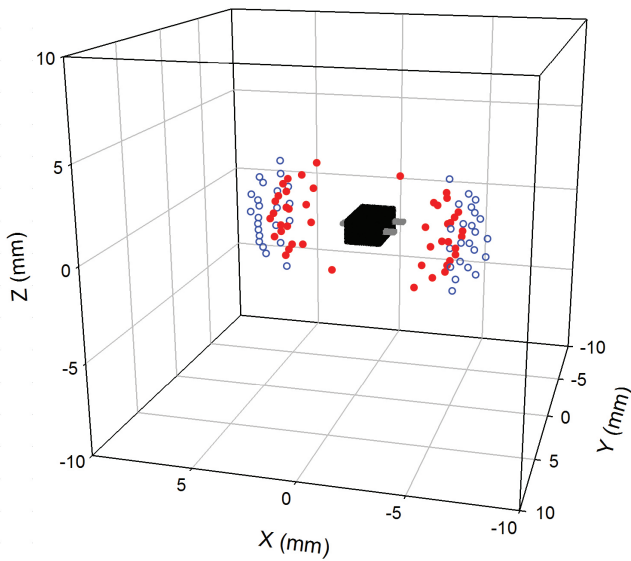

RR120/RR130 Magnetic Sensitivity Pattern, YZ plane

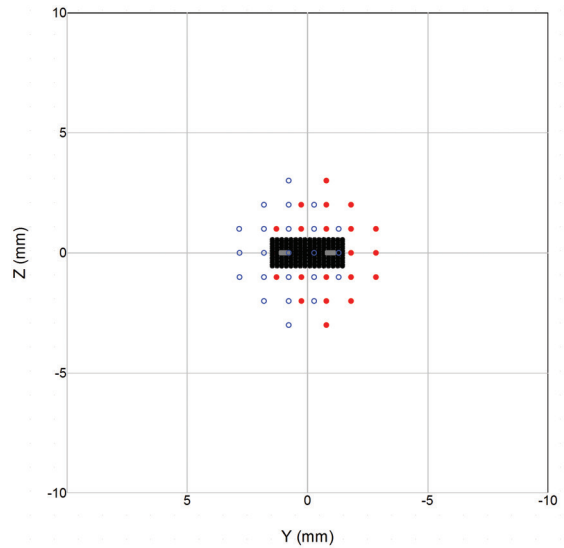

- Operate Points
- Release Points

RR120/RR130 Magnetic Sensitivity Pattern, XY plane

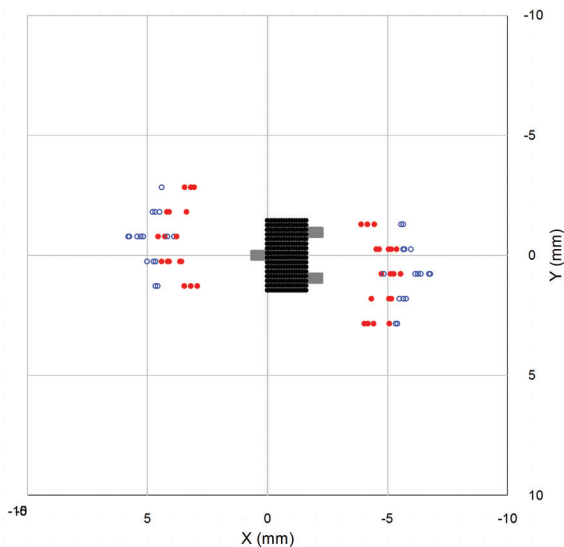

RR120/RR130 Magnetic Sensitivity Pattern, XZ plane

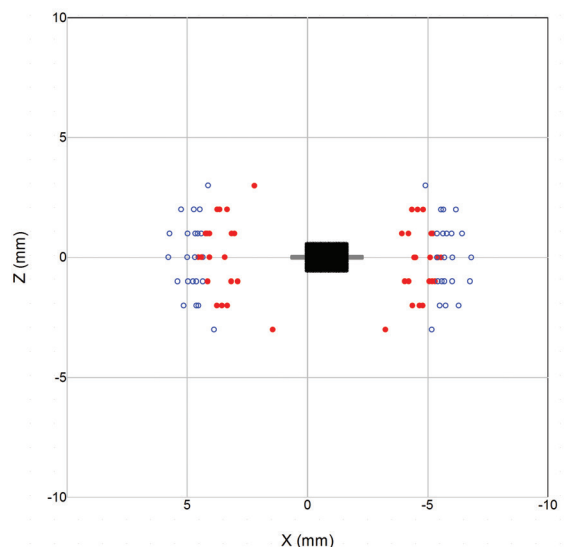



66 Whitecap Drive
North Kingstown, RI 02852
401-943-2686 • Fax: 401-942-0920
www.cotorelay.com • redrock@cotorelay.com